

***Analysis and Design of Analog Integrated Circuits***  
***Lecture 5***

***Single Stage Amplifiers***

**Michael H. Perrott**

**February 6, 2011**

**Copyright © 2011 by Michael H. Perrott**

**All rights reserved.**

# From Lecture 4: Proposed Thevenin Model for Transistor

### Hybrid- $\pi$ Model

Note:  $g_{mb} = 0$  if  $R_S = 0$  or  $V_{sb} = 0$

### Key Small-Signal Parameters

Parameter	Strong Inversion	Weak Inversion
$g_m$	$\sqrt{2\mu_n C_{ox}(W/L)I_D}$	$\frac{qI_D}{nkT}$
$g_{mb}$	$\frac{\gamma g_m}{2\sqrt{2 \Phi_F  + V_{SB}}}$	$\frac{(n-1)qI_D}{nkT}$
$r_o$	$\frac{1}{\lambda I_D}$	$\frac{1}{\lambda I_D}$

### Thevenin Resistances

### Exact

$$R_{thd} = r_o (1 + (g_m + g_{mb})R_S) + R_S$$

$$R_{thg} = \text{infinite}$$

$$R_{ths} = (1 + R_D/r_o) \left( r_o \parallel \frac{1}{g_m + g_{mb}} \right)$$

---

### Approximation ( $g_{mb} \ll g_m, g_m r_o \gg 1$ )

$$R_{thd} = r_o (1 + g_m R_S)$$

$$R_{thg} = \text{infinite}$$

$$R_{ths} = \frac{1 + R_D/r_o}{g_m} \approx \frac{1}{g_m} \quad (R_D \ll r_o)$$

### Proposed Small Signal Transistor Model

Exact	Approximation
$A_v = g_m r_o \parallel \frac{g_m}{g_m + g_{mb}}$	$A_v = 1 \quad (g_{mb} \ll g_m, g_m r_o \gg 1)$
$\alpha = 1 + R_D/R_{thd}$	$\alpha = 1 \quad (R_D \ll R_{thd})$

# A General View of Signal Flow in an Open Loop Device

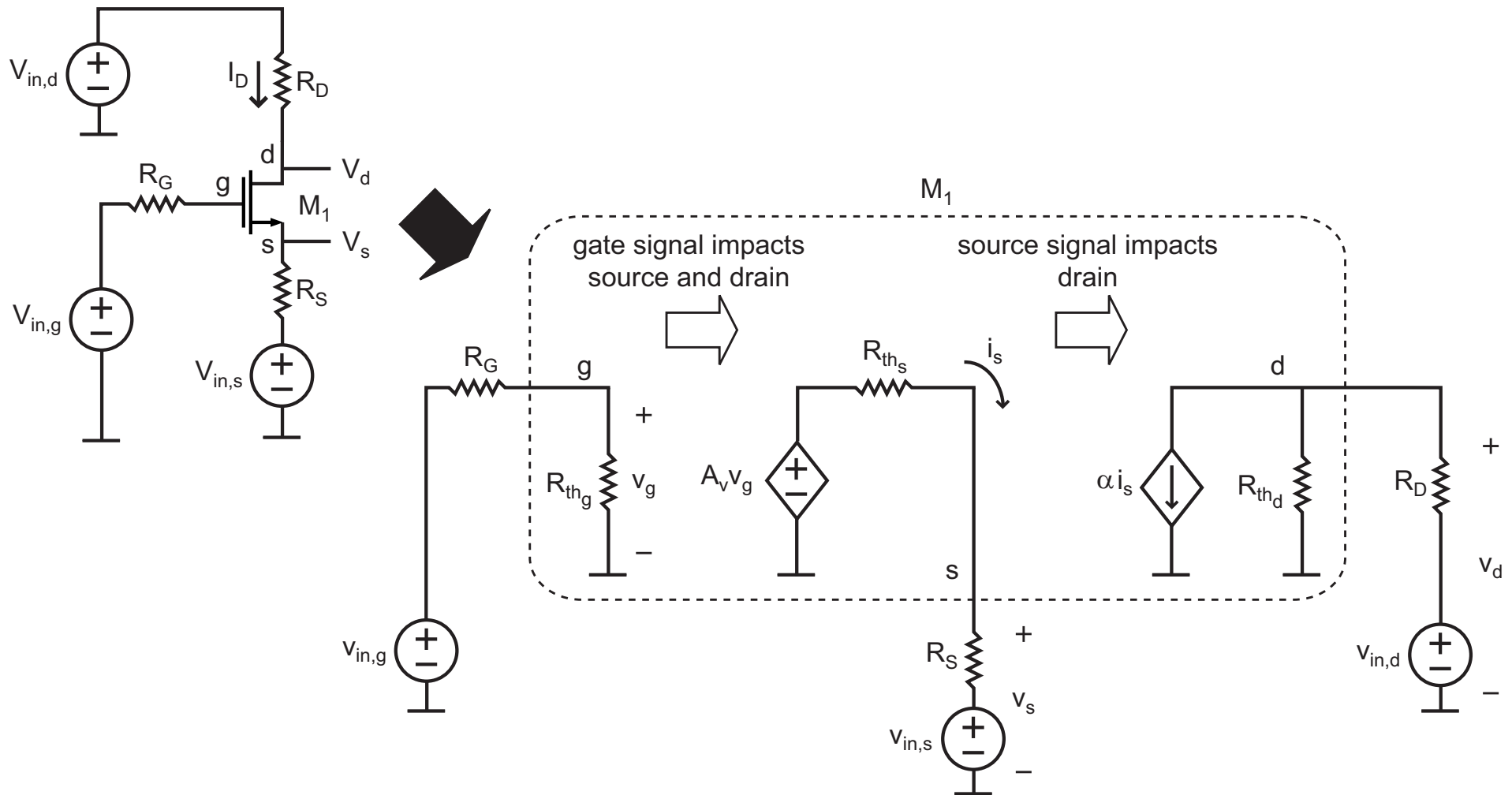

- To first order, influence of signals go from gate to source or from gate and/or source to drain
- This is only true when the device is in saturation

# ***Why is a CMOS Transistor Useful?***

---

- **Key properties of a transistor:**
  - **Converts voltage to current**
  - **Funnels current between different impedance domains**
- **The above properties allow us to build amplifiers in creative ways**
  - **A number of circuit topologies are possible**
  - **A good designer can leverage the right topology to achieve the best performance for a given application**

# Basic Single-Stage CMOS Amplifiers

Common Source

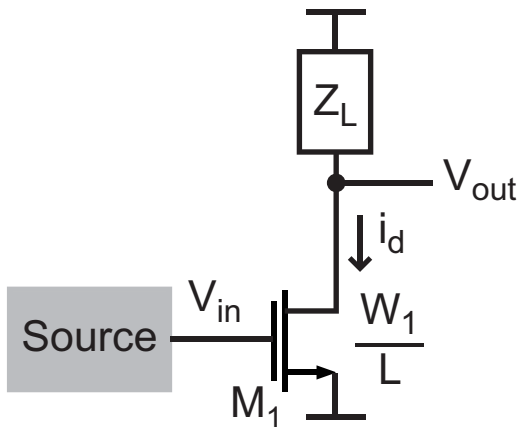

Common Gate

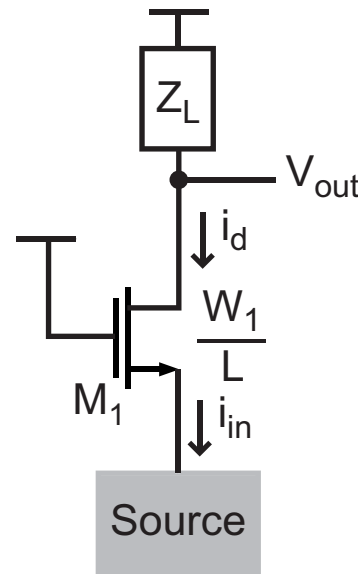

Source Follower

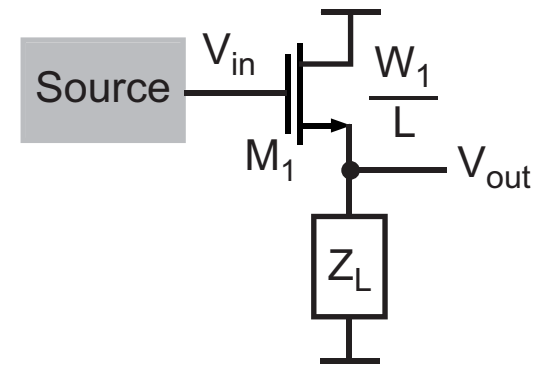

Common Source with Source Degeneration

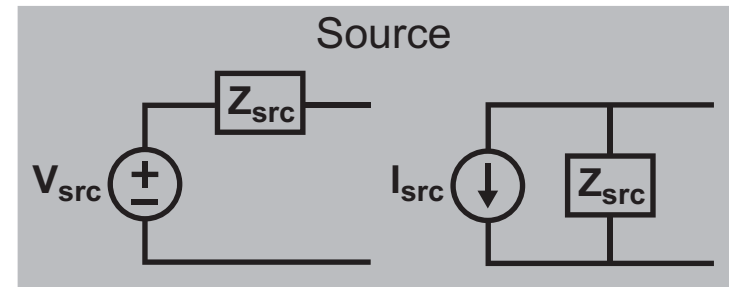
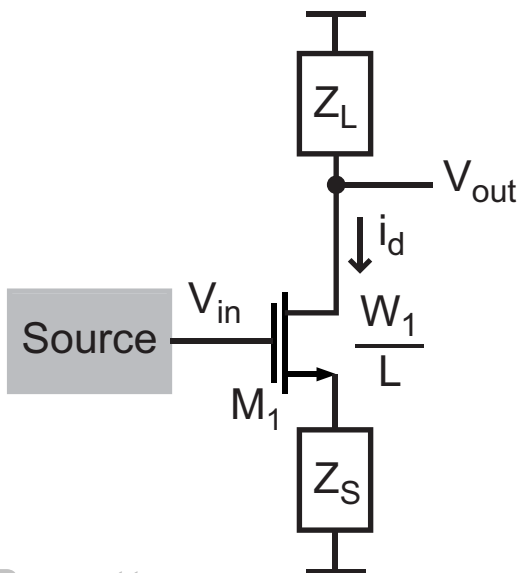

## Example: The Impact of Low Input Impedance

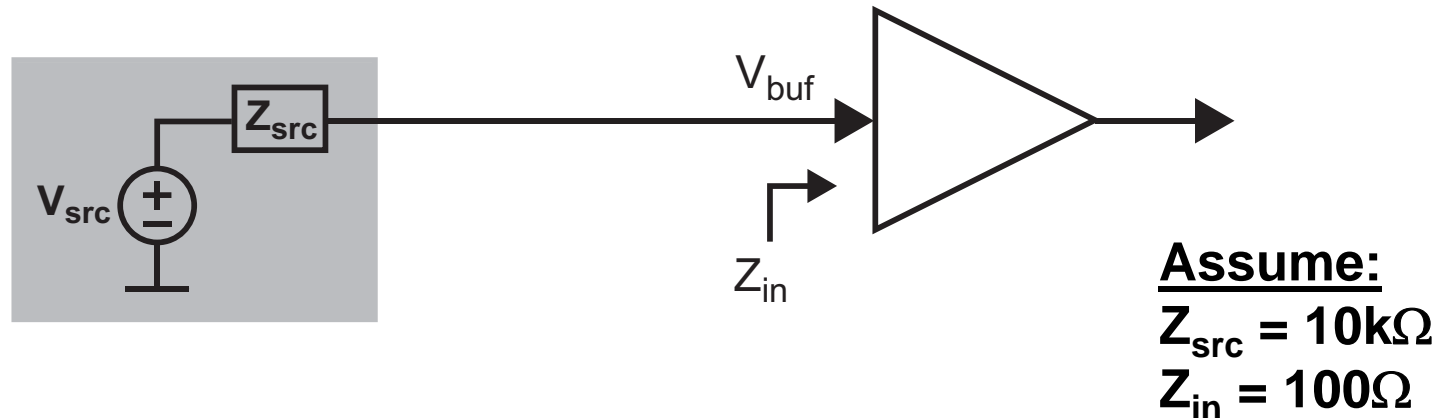

- Here we consider how the gain is influenced by having a source with large impedance driving a circuit with low input impedance
  - Calculate the gain from  $V_{src}$  to  $V_{buf}$
  - What is the impact of low  $Z_{in}$  and high  $Z_{src}$ ?

**What type of amplifier stage would alleviate the impact of having high source impedance and low input impedance?**

# Consider a Source Follower Circuit

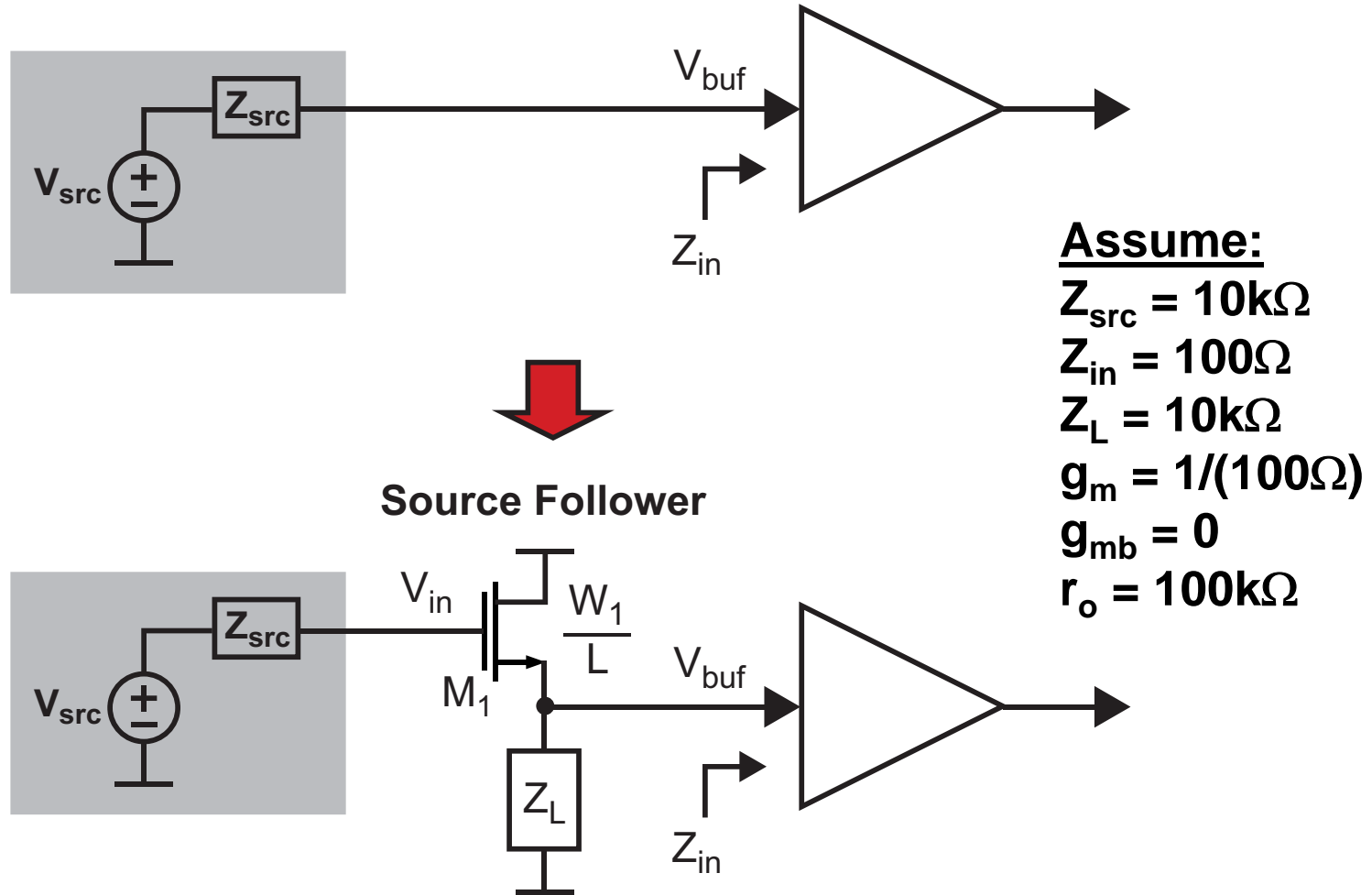

- Calculate the gain from  $V_{src}$  to  $V_{buf}$
- How did the source follower improve the situation?

## Example: The Impact of Low Source Impedance



### Assume:

$$Z_{src} = 100\Omega$$

$$Z_{in} = 1k\Omega$$

- Calculate the gain from  $I_{src}$  to  $V_{buf}$
- What is the impact of low  $Z_{src}$ ?

What type of amplifier stage would alleviate the impact of having low source impedance?

# Consider a Common Gate Amplifier



Common Gate

**Assume:**

$$Z_{src} = 100\Omega$$

$$Z_{in} = 1k\Omega$$

$$Z_L = 10k\Omega$$

$$g_m = 1/(100\Omega)$$

$$g_{mb} = 0$$

$$r_o = 100k\Omega$$

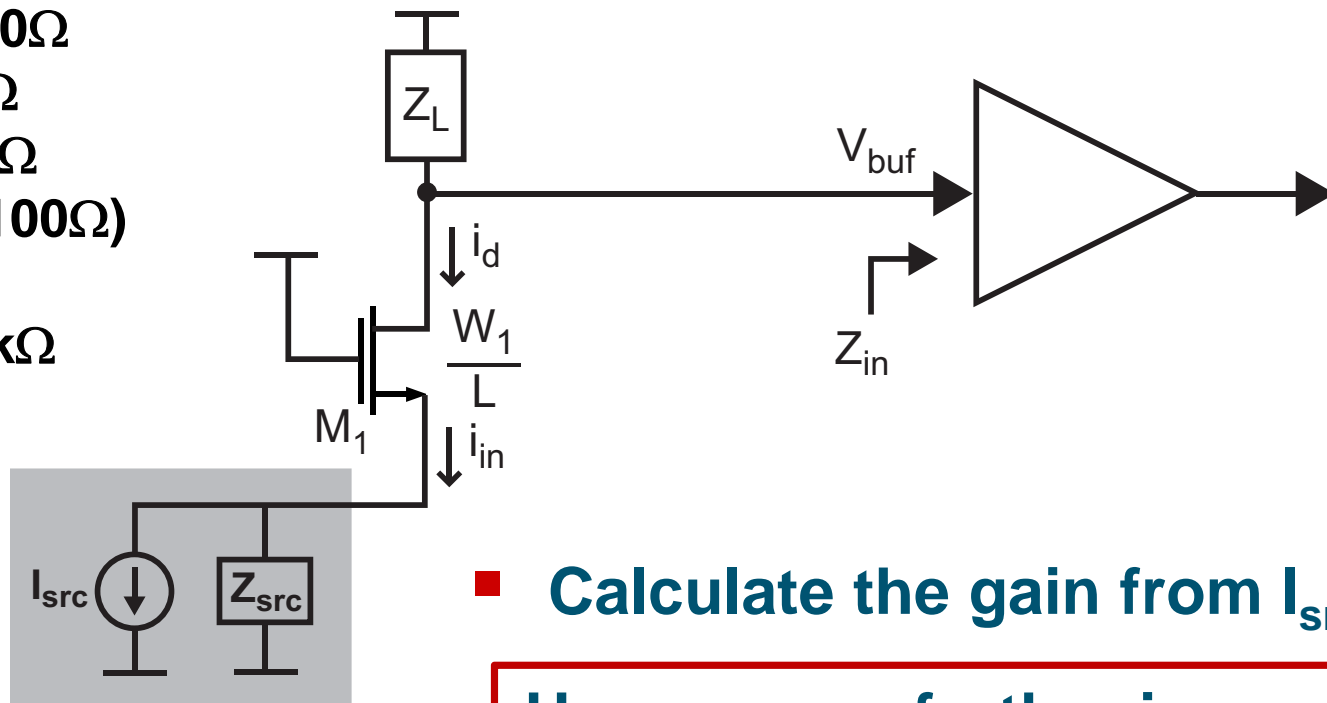

- Calculate the gain from  $I_{src}$  to  $V_{buf}$

How can we further improve gain?

# Add a Source Follower



Common Gate

Source Follower

**Assume:**

$$Z_{src} = 100\Omega$$

$$Z_{in} = 1k\Omega$$

$$Z_L = 10k\Omega$$

$$g_m = 1/(100\Omega)$$

$$g_{mb} = 0$$

$$r_o = 100k\Omega$$

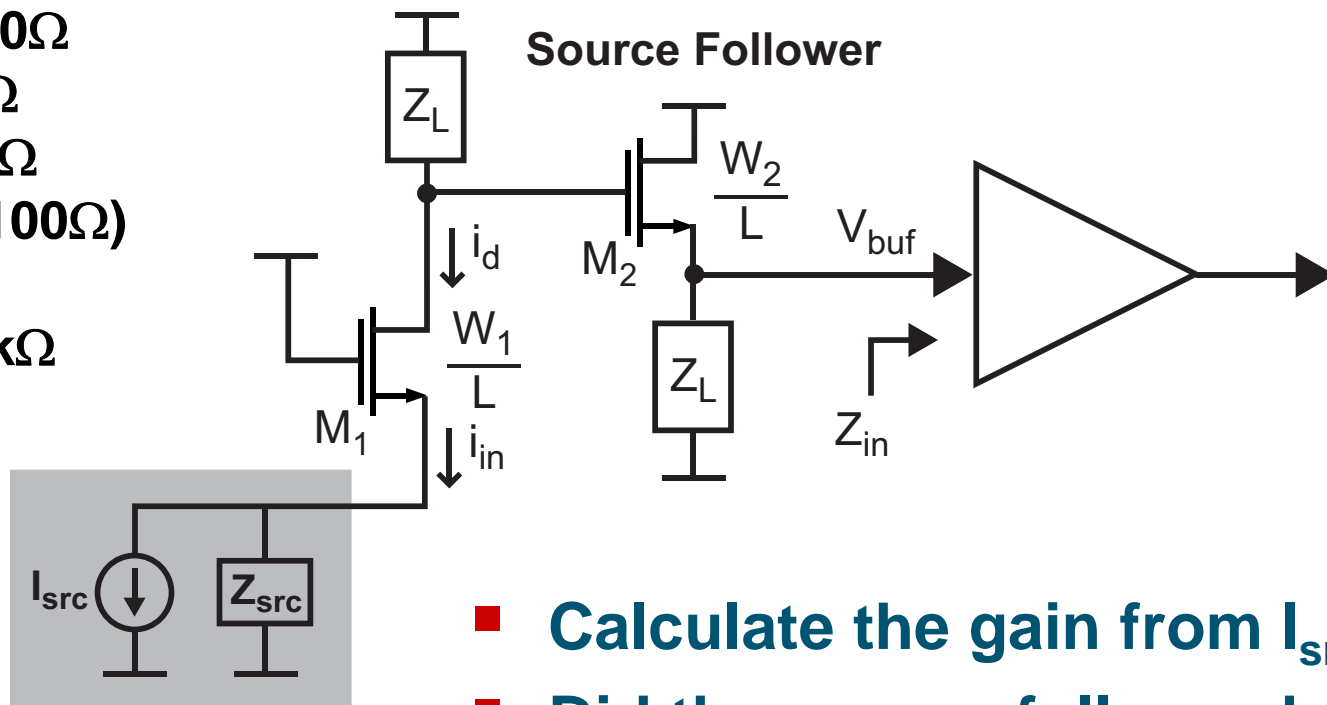

- Calculate the gain from  $I_{src}$  to  $V_{buf}$
- Did the source follower help?

# Consider Using a Common Source Amplifier Instead

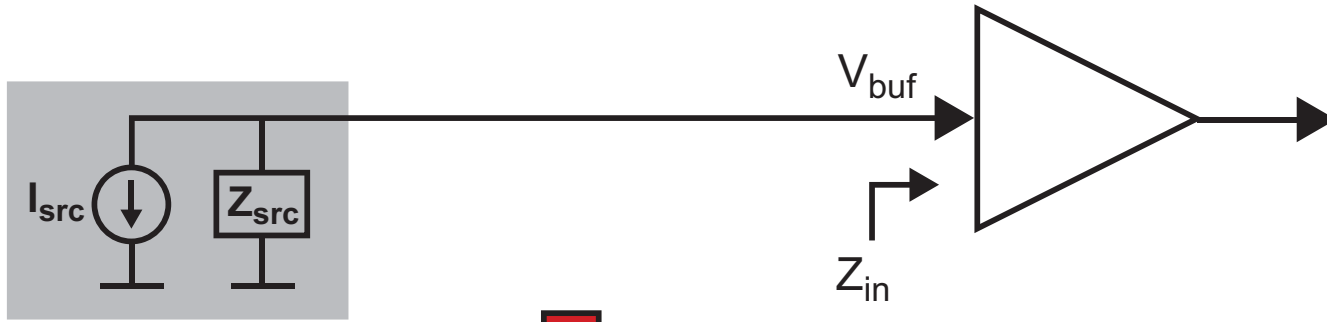

**Assume:**

$$Z_{src} = 100\Omega$$

$$Z_{in} = 1k\Omega$$

$$Z_L = 10k\Omega$$

$$g_m = 1/(100\Omega)$$

$$g_{mb} = 0$$

$$r_o = 100k\Omega$$

**Common Source**

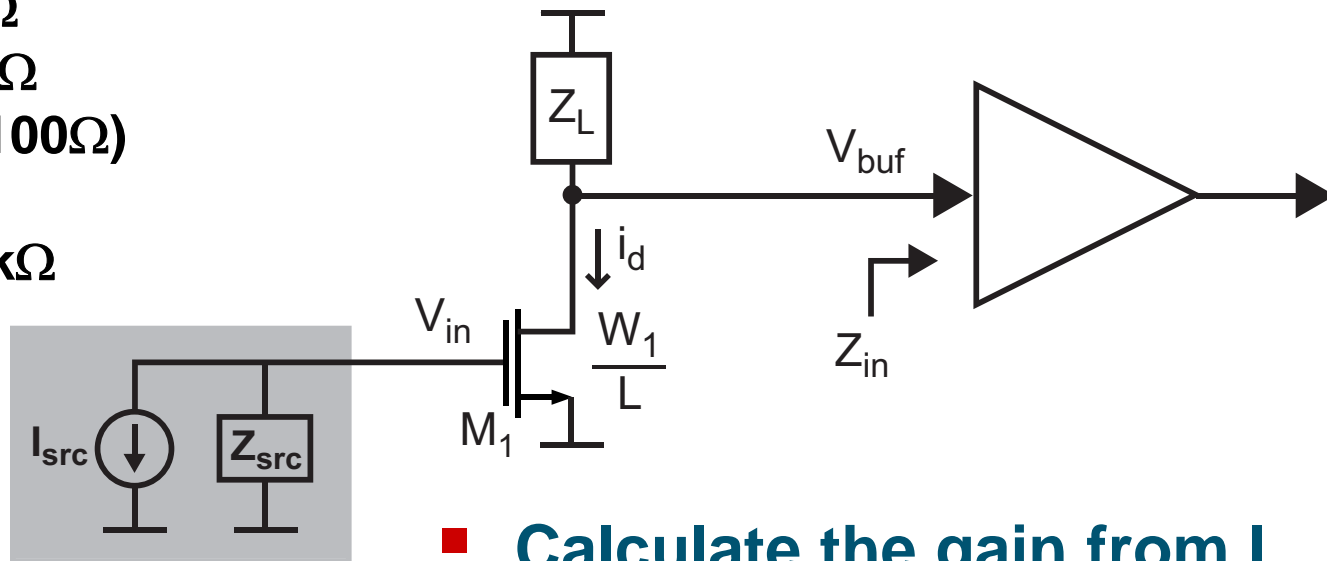

- Calculate the gain from  $I_{src}$  to  $V_{buf}$

**How does the common gate approach compare to this?**